

AVRO LANCASTER B.Mk.I/III



History | 历史介绍

Avro Lancaster B.Mk.I/III

The first Lancaster equipped was 41 Squadron, first participated in the bombing of Haligonad Eight mine on March 3, 1942, then participated in the night lighting bombing of Essen, Cologne, Duisburg, and Düsseldorf in the Ruhr area of Germany between March and June 1942, especially the 3 times of "Thousand-bomber raids", the first in the history of the war. According to the data: the bombing of Cologne on the night of May 30, a total of 1046 aircraft, 1455 tons of bombs, lasting 90 minutes, 2/3 of which were incendiary bombs, the entire city of Cologne 40 hectares were razed to the ground, resulting in 499 people killed, 5227 people injured, 142,000 people homeless consequences. It was the most effective British bombing since they changed from target bombing to area bombing. But its significance far not in these damage effects achieved, nor in the effect on the morale of the German military and civilian population. It marked the beginning of a massive British bombing campaign against Germany, forcing Germany to fight on a complex front. Germany had to strengthen the air defenses in the homeland, making the use of air power extremely fragmented and careless.

The first Lancaster equipped was 41 Squadron, first participated in the bombing of Haligonad Eight mine on March 3, 1942, then participated in the night lighting bombing of Essen, Cologne, Duisburg, and Düsseldorf in the Ruhr area of Germany between March and June 1942, especially the 3 times of "Thousand-bomber raids", the first in the history of the war. According to the data: the bombing of Cologne on the night of May 30, a total of 1046 aircraft, 1455 tons of bombs, lasting 90 minutes, 2/3 of which were incendiary bombs, the entire city of Cologne 40 hectares were razed to the ground, resulting in 499 people killed, 5227 people injured, 142,000 people homeless consequences. It was the most effective British bombing since they changed from target bombing to area bombing. But its significance far not in these damage effects achieved, nor in the effect on the morale of the German military and civilian population. It marked the beginning of a massive British bombing campaign against Germany, forcing Germany to fight on a complex front. Germany had to strengthen the air defenses in the homeland, making the use of air power extremely fragmented and careless.

On the night of May 16-17 May, Lancasters of the 617th Bomb Squadron flew a mission code-named "Operation Chastise" -- to attack dams around German industrial centers, thereby destroying German military industrial production. "Operation Chastise", as it became known, required the use of newly designed cylindrical bombs, which had to be flown at ultra-low altitudes and at precise speeds to ensure that the cylindrical bombs would burst the water and descend along the dam wall to explode at the bottom of the dam. After continuous flight lasting over the valleys and reservoirs of Sh-shold and Manchester, the ULP reservoir was controlled and the "bump-bomb" were assembled, it was not until 11:15 that the crews learned that the purpose of the light training was to attack the German dams, which many of the crews had previously thought was a tactical way to attack enemy targets.

A number of improvements were made in the Lancaster bombers in service in the Far East, primarily modifying the fuselage to increase fuel capacity and thus range. For example, additional fuel tanks were added to the fuselage and even an aerial refueling collar was considered. Until finally, the increased model was recognized as the Liberator bomber due to the use of a completely different engine and self-defense weapon mounting.

As the war in Europe drew to a close, Lancaster bombers operated close to the heart of Germany. The last recorded sortie was the bombing of Hitler's Berlin bunker on April 25, 1945, and many night attacks on Nuremberg by the Luftwaffe. By the end of the war, the Lancasters had flown 152,000 sorties, and in April 1945 RAF Bomber Command had 745 front-line combat squadrons with 416 bombers and a further 204 aircraft for training. After the Armistice most of these aircraft were used to transport prisoners of war, a total of 75,000 men.

With the advent of the post-war peace era, some aircraft were modified and equipped for the Tigers deployed in Burma. Meanwhile, others were fitted with photographic reconnaissance equipment in 1948 and served with the 72nd Bomb Squadron and the 82nd Bomb Squadron in East, Central and West Africa. A number of Lancaster bombers were also converted for air and sea rescue missions. The Lancasters, which were part of the Air Force Naval Defence Group, were based in Malta and flew maritime reconnaissance missions until the last aircraft returned to the museum in February 1954. However, a Lancaster MK3, number 1N225, Serbia, last mission until October 13, 1956.

But that didn't mean the end of the Lancaster story. A significant number of Lancaster 10 bombers served with the Canadian Air Force in a variety of roles, including aerial survey, all-Asia rescue and maritime reconnaissance. In Canada, the Lancaster remained in service until April 3, 1964, which is amazing. Other foreign users of Lancasters include Argentina (15 refurbished) and France, where a total of 34 Lancasters served with the French Navy.

Despite the huge production numbers, only two still flying Lancasters have survived to this day. The Lancaster was assembled from parts provided by the Canadian Military Aircraft Museum and made its first flight after reconstruction in 1950.

1938年5月，兰开斯特飞机诞生。1942年3月23日，第一次世界大战后，英国皇家空军在比利时建立了兰开斯特飞机制造厂。在战争期间，兰开斯特飞机在北海、波罗的海、北海、北海和北海“午夜轰炸”，摧毁了德国的工业基地。在战争期间，兰开斯特飞机在北海、波罗的海、北海、北海和北海“午夜轰炸”，摧毁了德国的工业基地。在战争期间，兰开斯特飞机在北海、波罗的海、北海、北海和北海“午夜轰炸”，摧毁了德国的工业基地。

1942年11月16日，兰开斯特飞机在北海上空执行了著名的“Operation Chastise”任务，摧毁了德国的工业基地。在战争期间，兰开斯特飞机在北海、波罗的海、北海、北海和北海“午夜轰炸”，摧毁了德国的工业基地。在战争期间，兰开斯特飞机在北海、波罗的海、北海、北海和北海“午夜轰炸”，摧毁了德国的工业基地。

1945年4月25日，兰开斯特飞机在柏林上空执行了最后一次任务。在战争期间，兰开斯特飞机在北海、波罗的海、北海、北海和北海“午夜轰炸”，摧毁了德国的工业基地。在战争期间，兰开斯特飞机在北海、波罗的海、北海、北海和北海“午夜轰炸”，摧毁了德国的工业基地。

1950年，兰开斯特飞机在北海上空执行了最后一次任务。在战争期间，兰开斯特飞机在北海、波罗的海、北海、北海和北海“午夜轰炸”，摧毁了德国的工业基地。在战争期间，兰开斯特飞机在北海、波罗的海、北海、北海和北海“午夜轰炸”，摧毁了德国的工业基地。

1964年，兰开斯特飞机在北海上空执行了最后一次任务。在战争期间，兰开斯特飞机在北海、波罗的海、北海、北海和北海“午夜轰炸”，摧毁了德国的工业基地。在战争期间，兰开斯特飞机在北海、波罗的海、北海、北海和北海“午夜轰炸”，摧毁了德国的工业基地。

1968年，兰开斯特飞机在北海上空执行了最后一次任务。在战争期间，兰开斯特飞机在北海、波罗的海、北海、北海和北海“午夜轰炸”，摧毁了德国的工业基地。在战争期间，兰开斯特飞机在北海、波罗的海、北海、北海和北海“午夜轰炸”，摧毁了德国的工业基地。

1972年，兰开斯特飞机在北海上空执行了最后一次任务。在战争期间，兰开斯特飞机在北海、波罗的海、北海、北海和北海“午夜轰炸”，摧毁了德国的工业基地。在战争期间，兰开斯特飞机在北海、波罗的海、北海、北海和北海“午夜轰炸”，摧毁了德国的工业基地。

1976年，兰开斯特飞机在北海上空执行了最后一次任务。在战争期间，兰开斯特飞机在北海、波罗的海、北海、北海和北海“午夜轰炸”，摧毁了德国的工业基地。在战争期间，兰开斯特飞机在北海、波罗的海、北海、北海和北海“午夜轰炸”，摧毁了德国的工业基地。

1980年，兰开斯特飞机在北海上空执行了最后一次任务。在战争期间，兰开斯特飞机在北海、波罗的海、北海、北海和北海“午夜轰炸”，摧毁了德国的工业基地。在战争期间，兰开斯特飞机在北海、波罗的海、北海、北海和北海“午夜轰炸”，摧毁了德国的工业基地。

零件 Parts

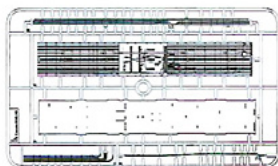
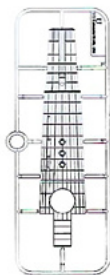
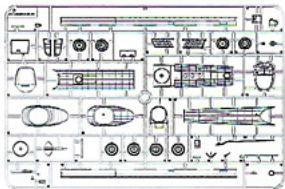
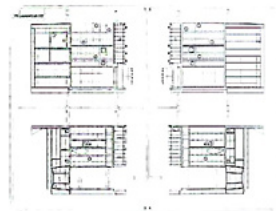

*4PCS

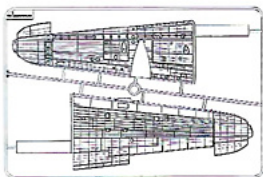
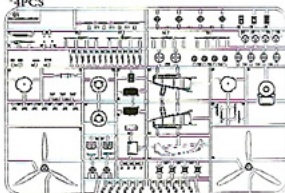

*4PCS



PE



Decal

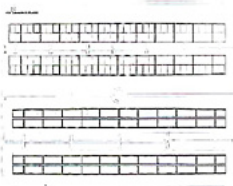
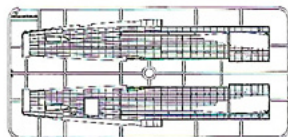

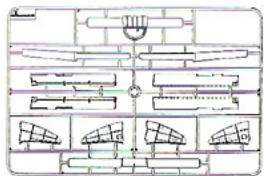
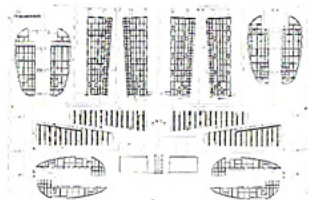
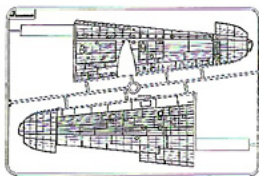
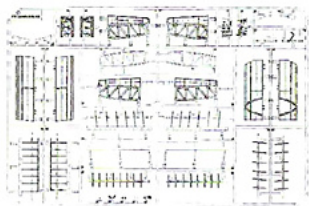
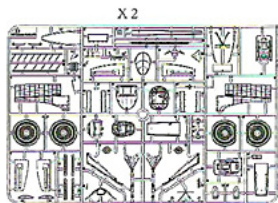
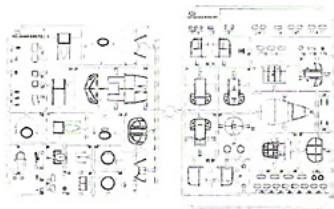
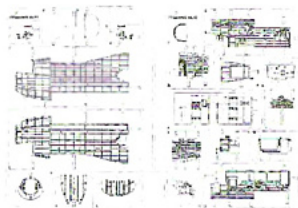

Pilot's seat and dashboard

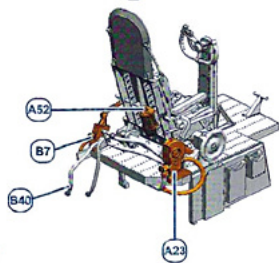
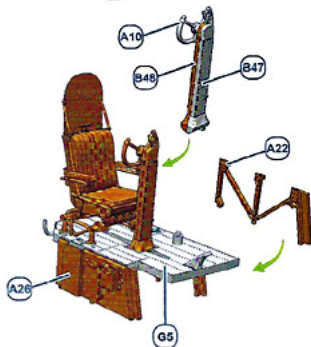
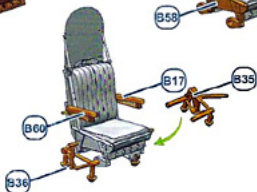

Photoetch Sutton Harness

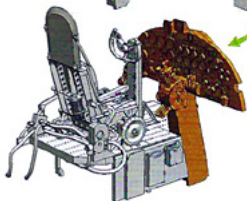
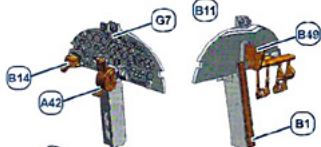
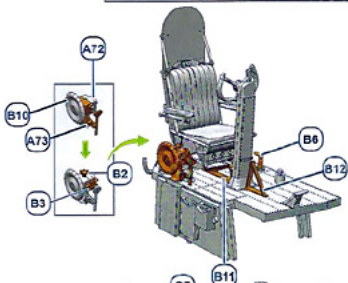
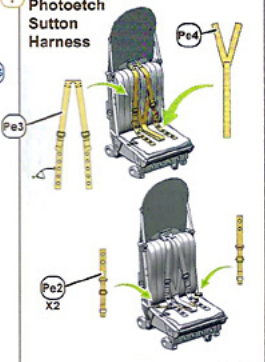

Port cockpit

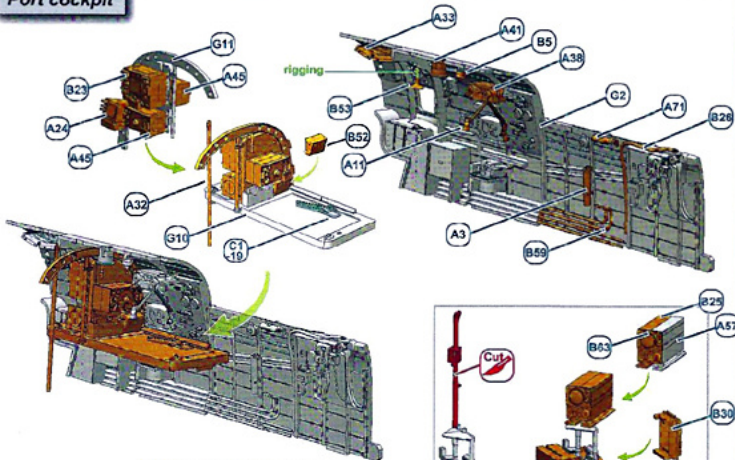

? Photoetch Harness

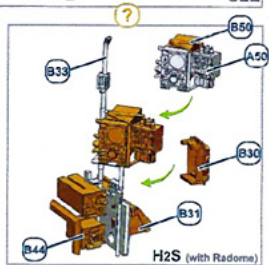
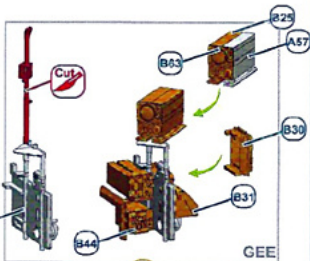
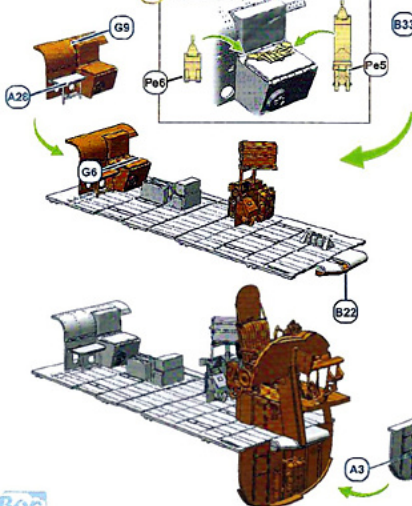

? Photoetch Harness

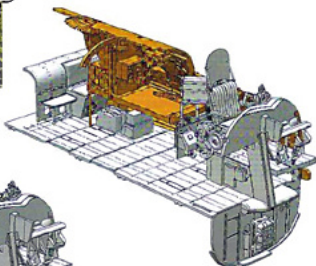
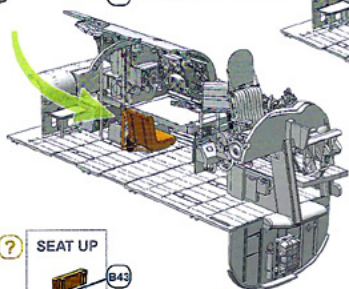

SEAT DOWN ?

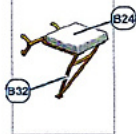

SEAT UP ?

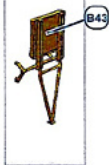

? Photoetch Backrest

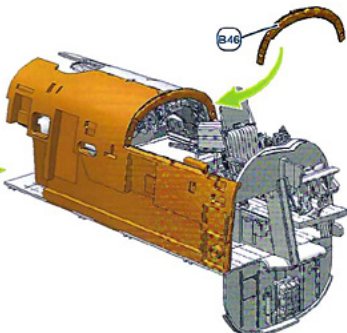
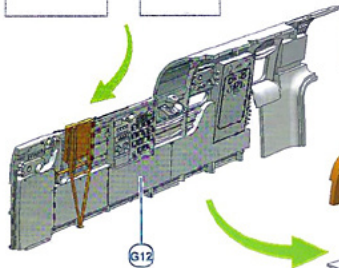
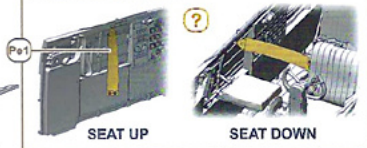

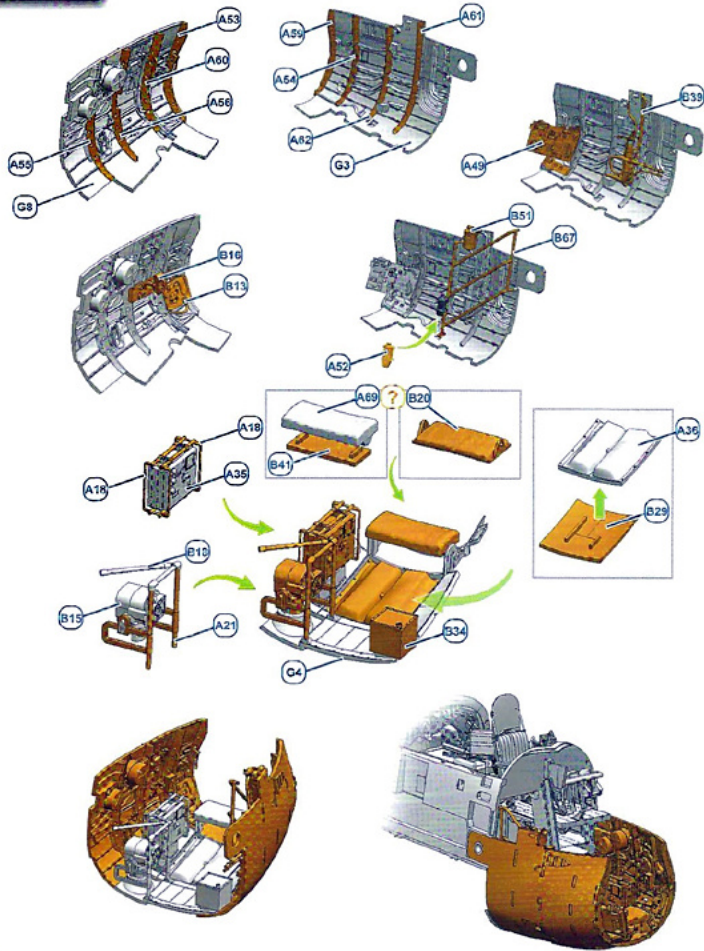

Nose Assembly

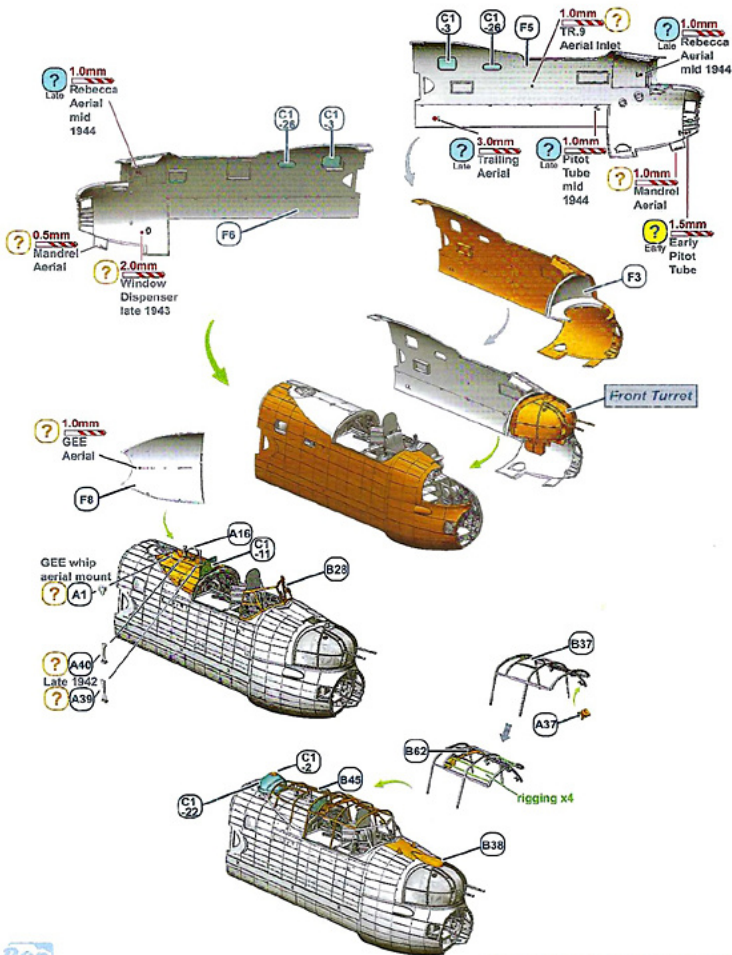

Front Turret

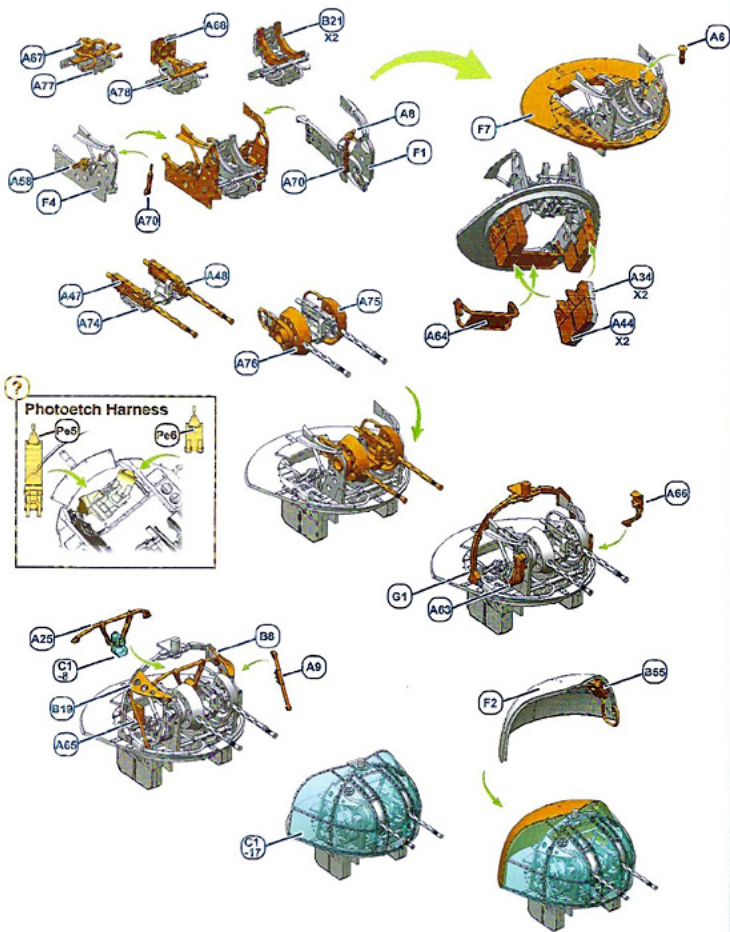

Nose Assembly

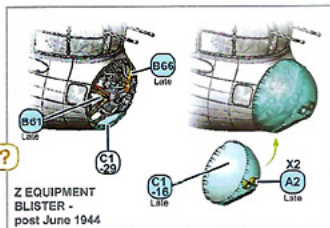
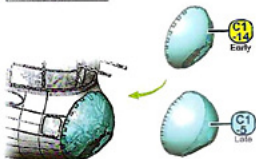
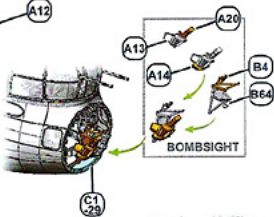
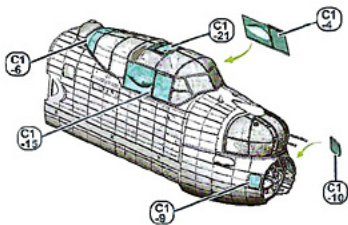
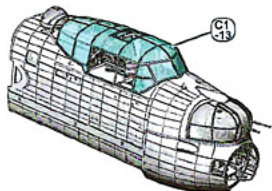

Bomb Bay

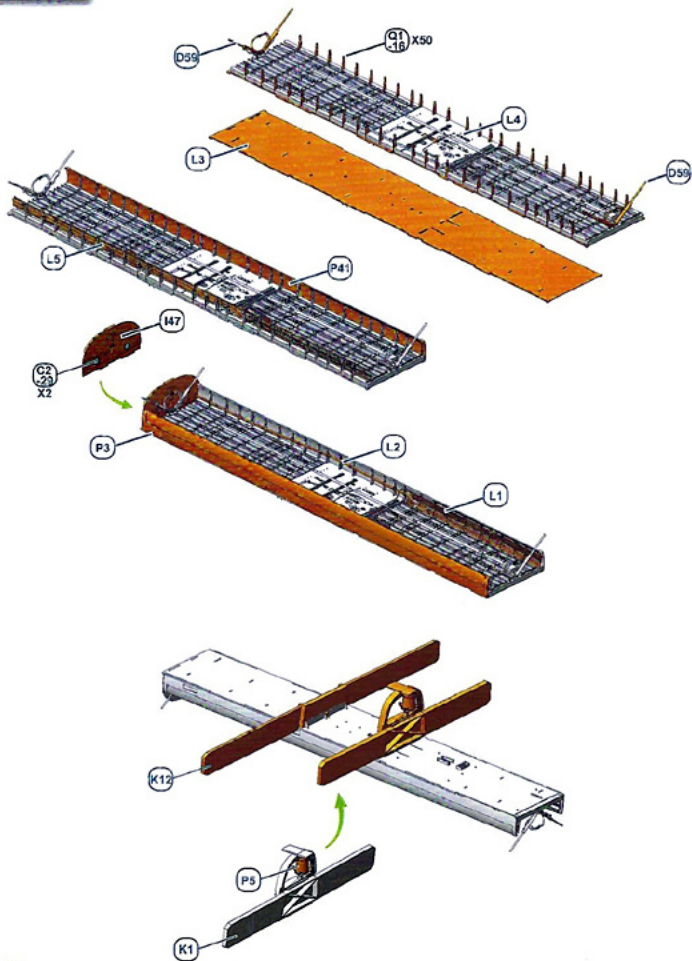

1x 4000lb + 12x Small Bomb Containers

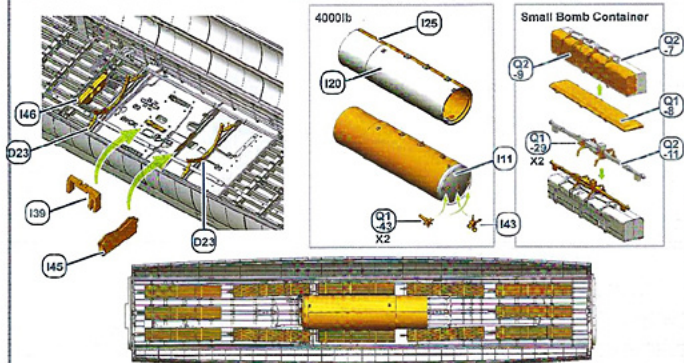

14x 500lb British Mk4 or American

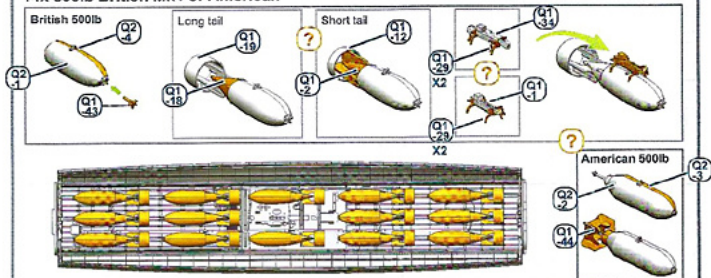

6x 1000lb MC British

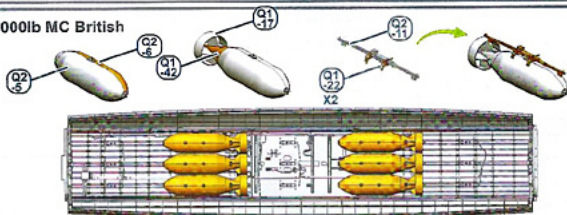

Rear Fuselage

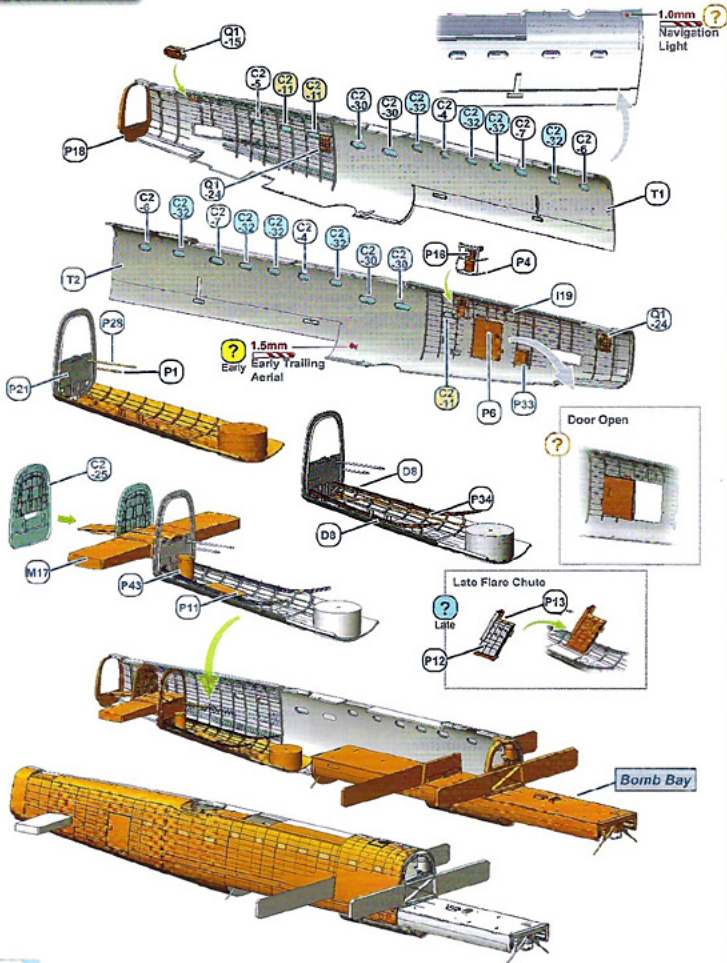

Rear Fuselage

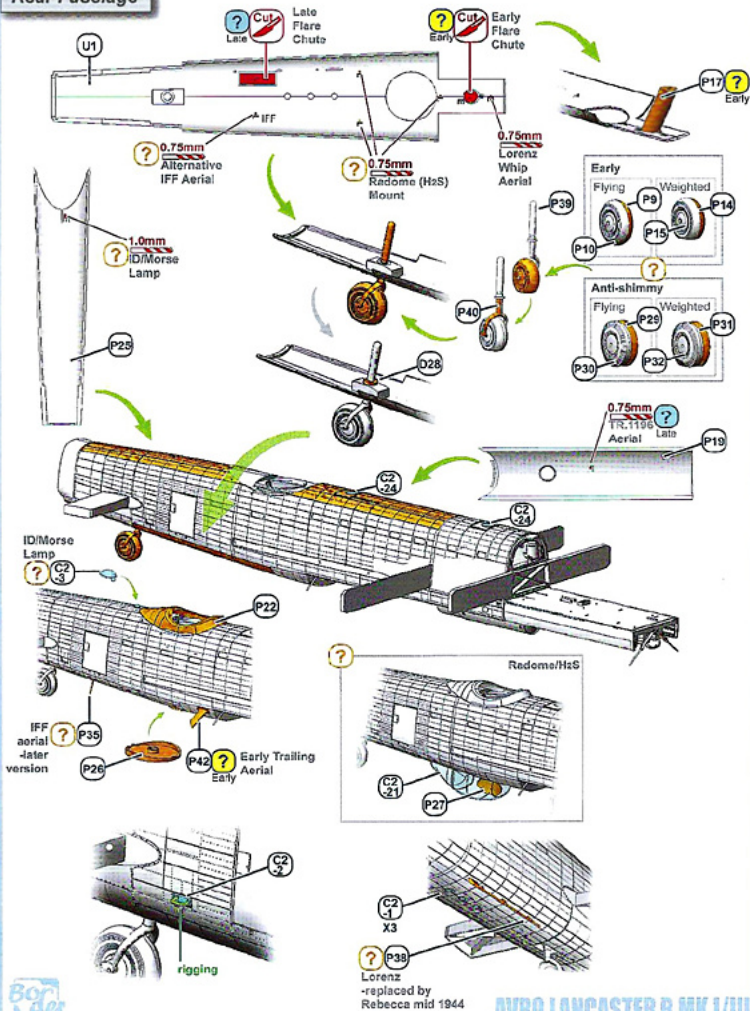

Starboard Inner Wing

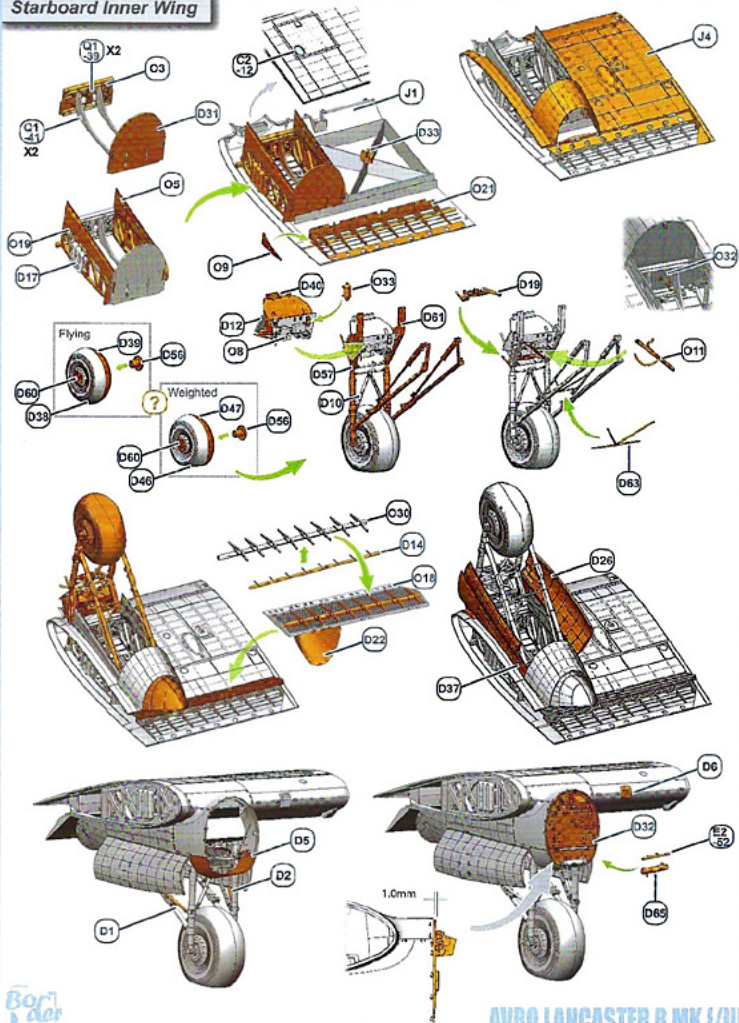

Port Inner Wing

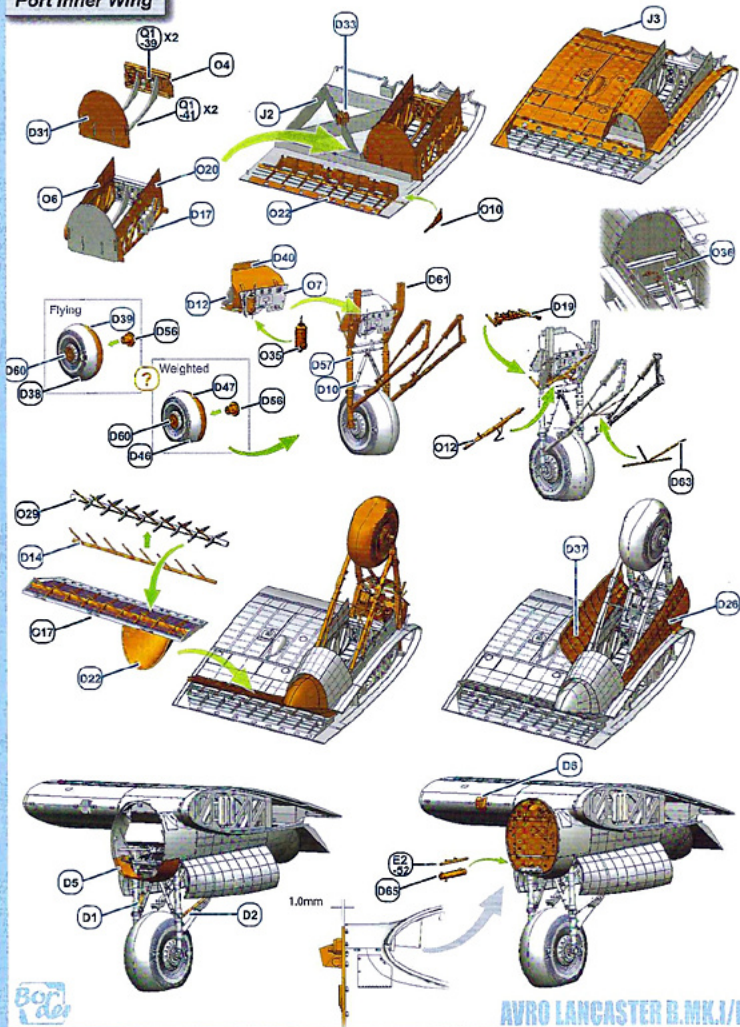

Engine

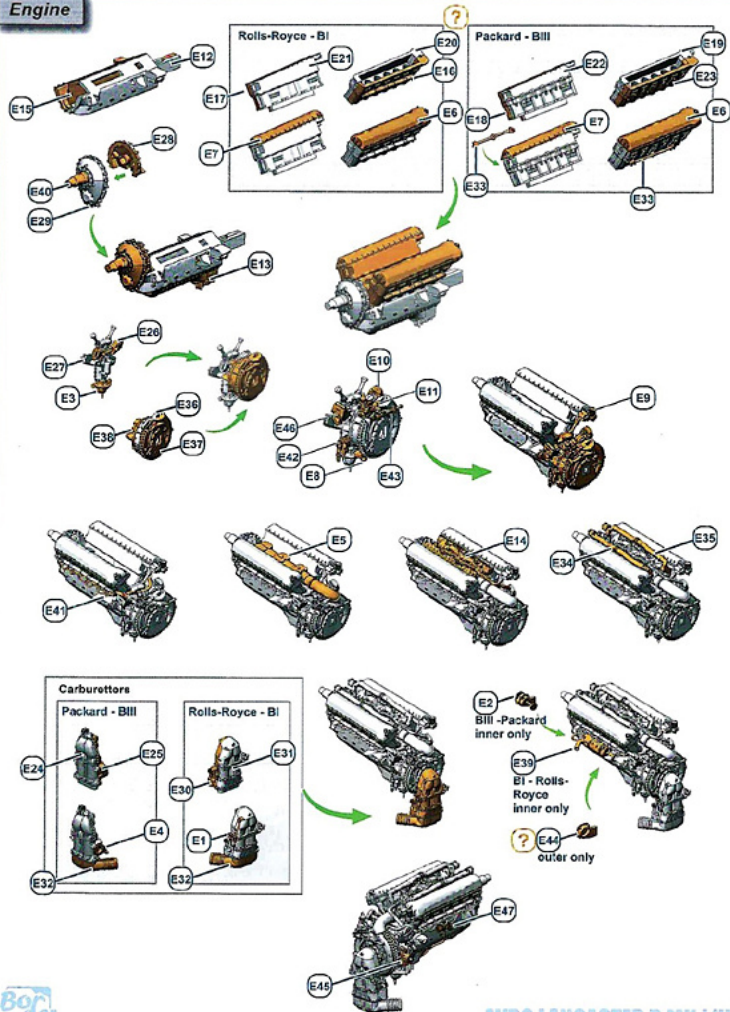

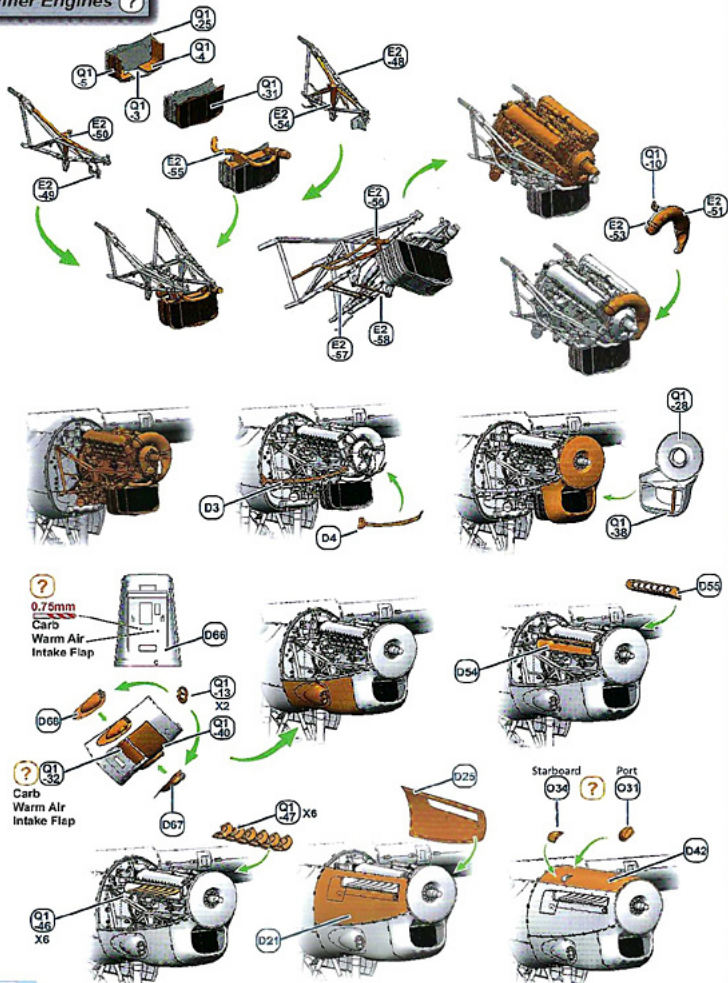

Port

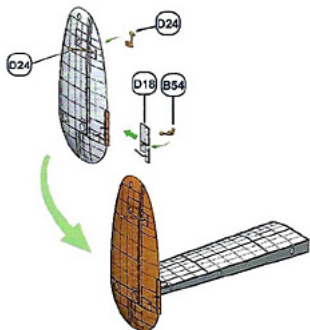
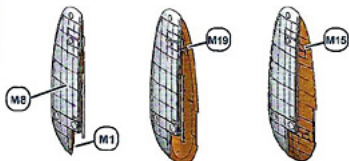
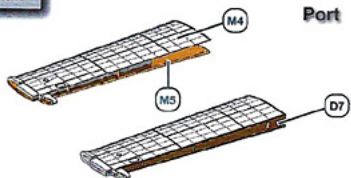

Port Elevator

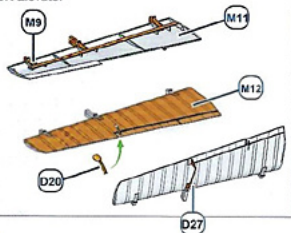

Starboard

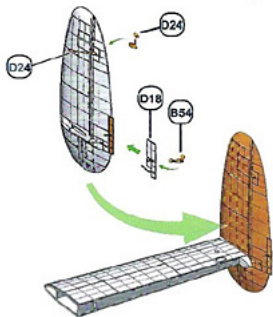
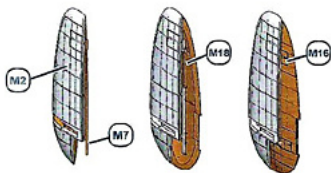
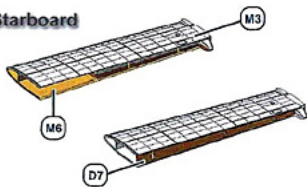

Starboard Elevator

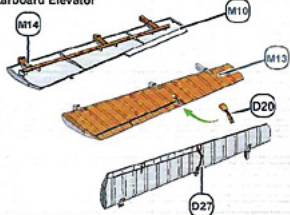

Upper Turret FN.50

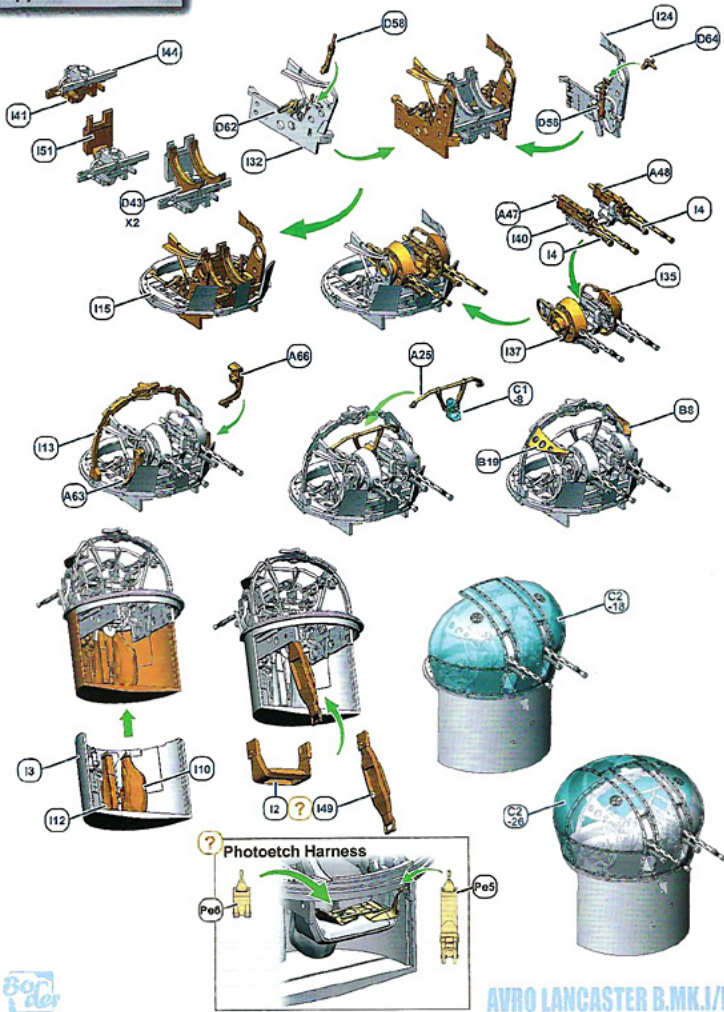

Rear Turret FN.20 Early (?)

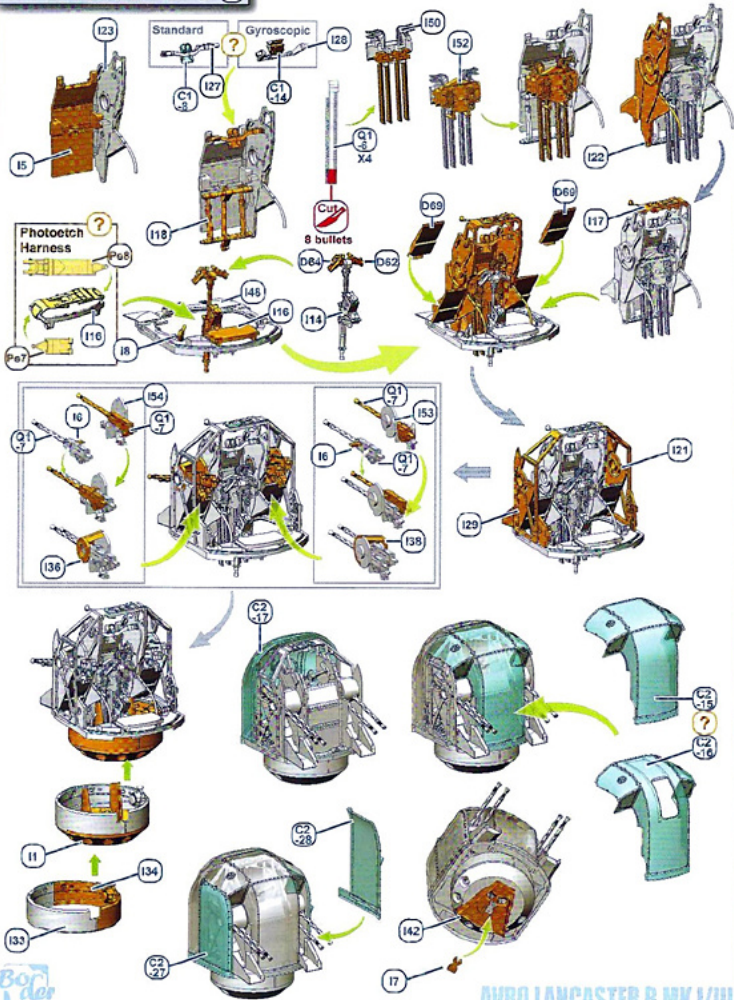

Rear Turret FN.120 Late (?)

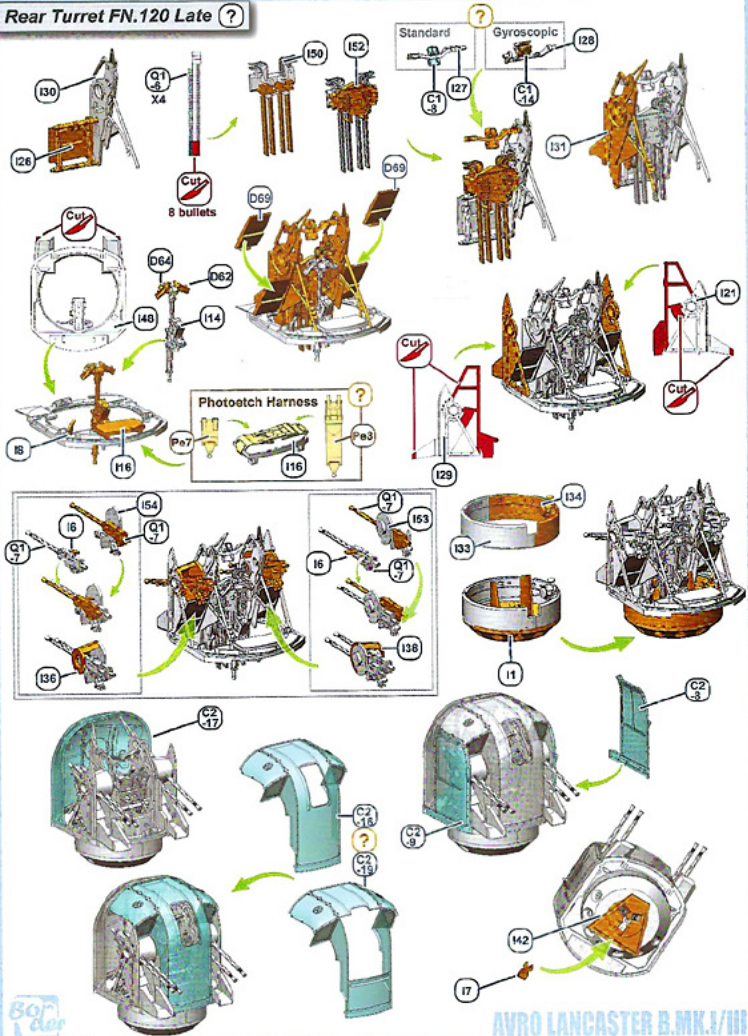

Outer Wings

Starboard

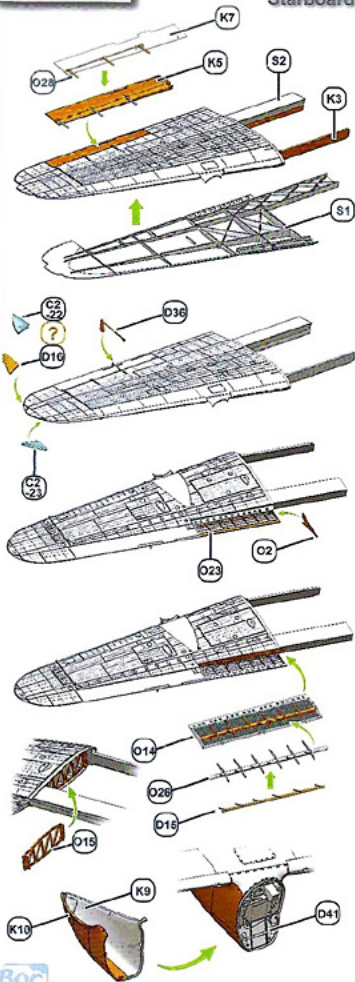

Port

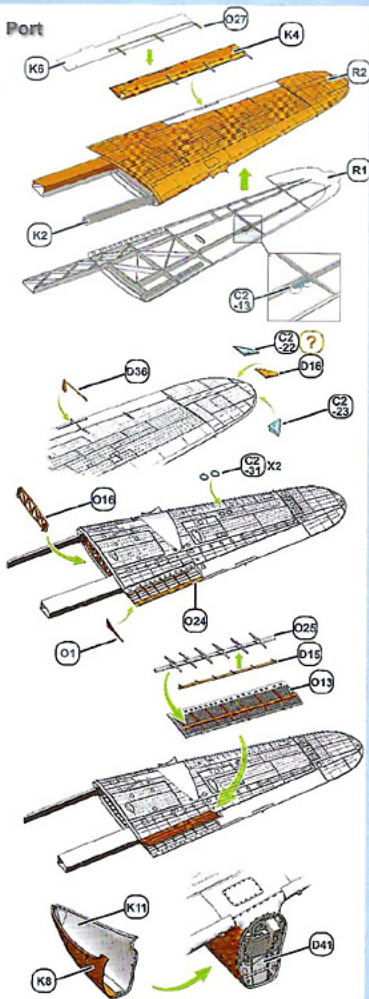

Outer Engines ?

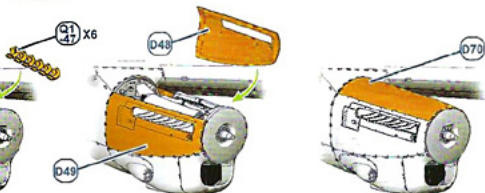
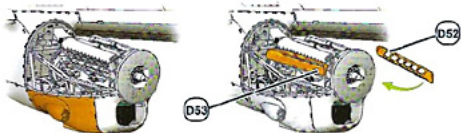
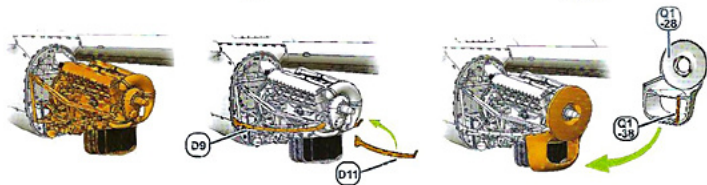
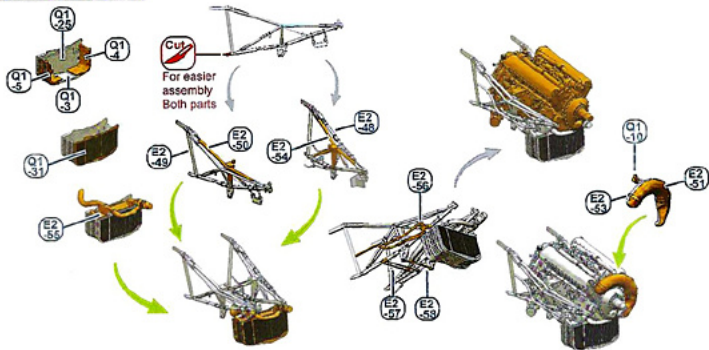

Dummy Engines ?

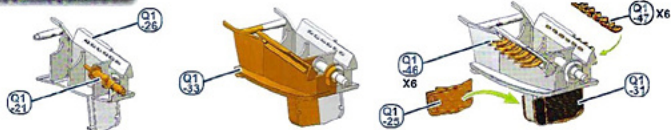

Inner

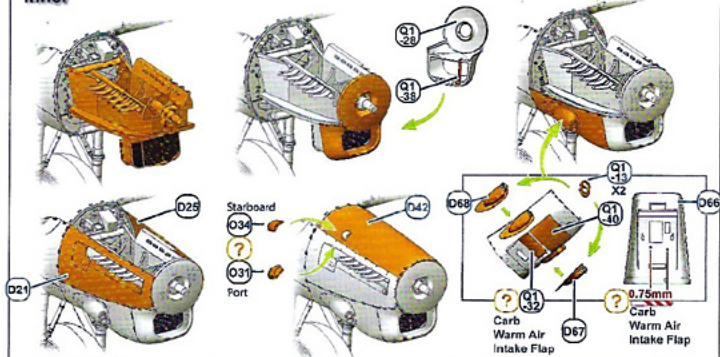

Outer

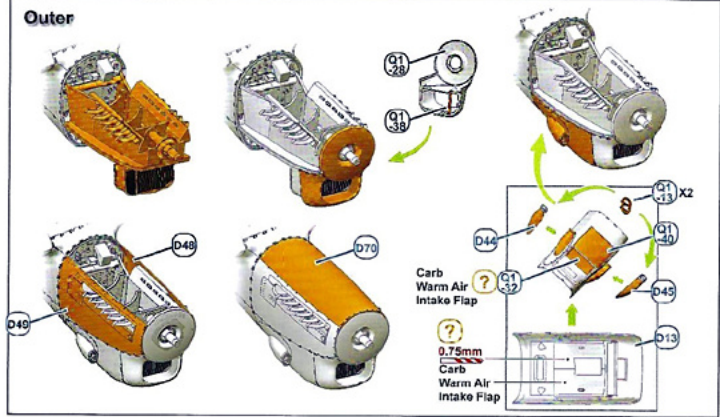

Final Assembly

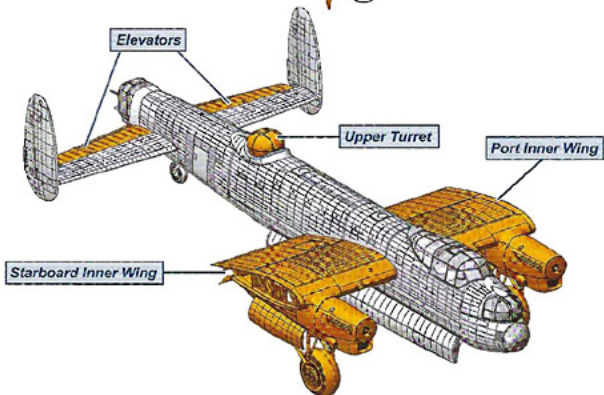
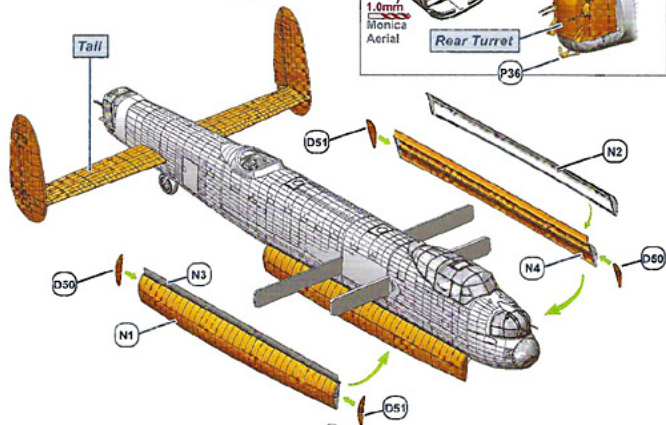
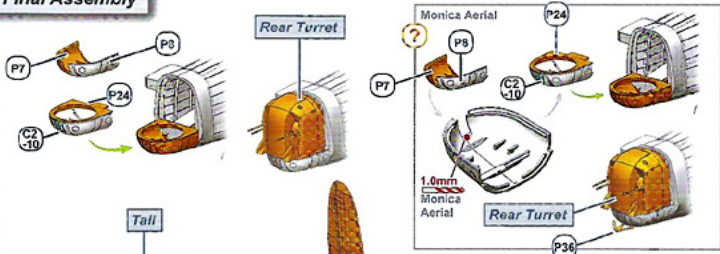

Final Assembly

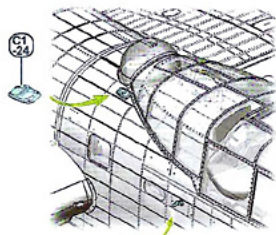
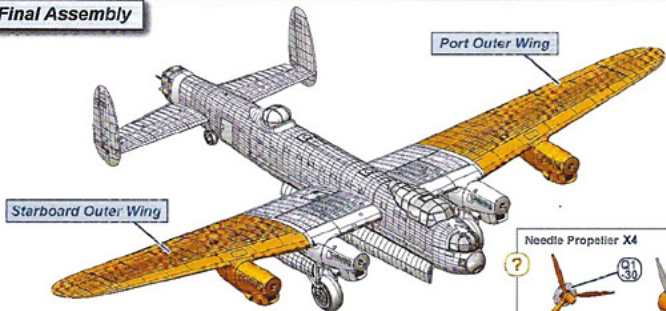

Drift Recorder A1

Paddle Propeller X4

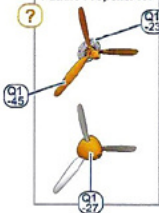

Needle Propeller X4

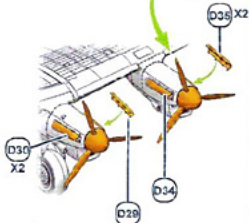

Rebecca Aerials - mid 1944, replaces Lorenz

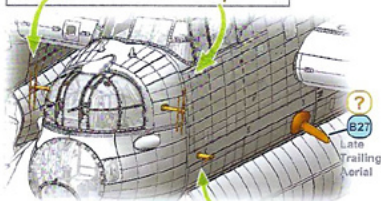

Optional External Parts
- airframe specific

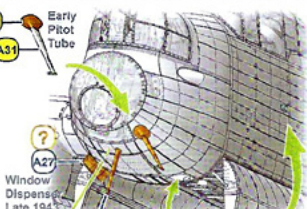

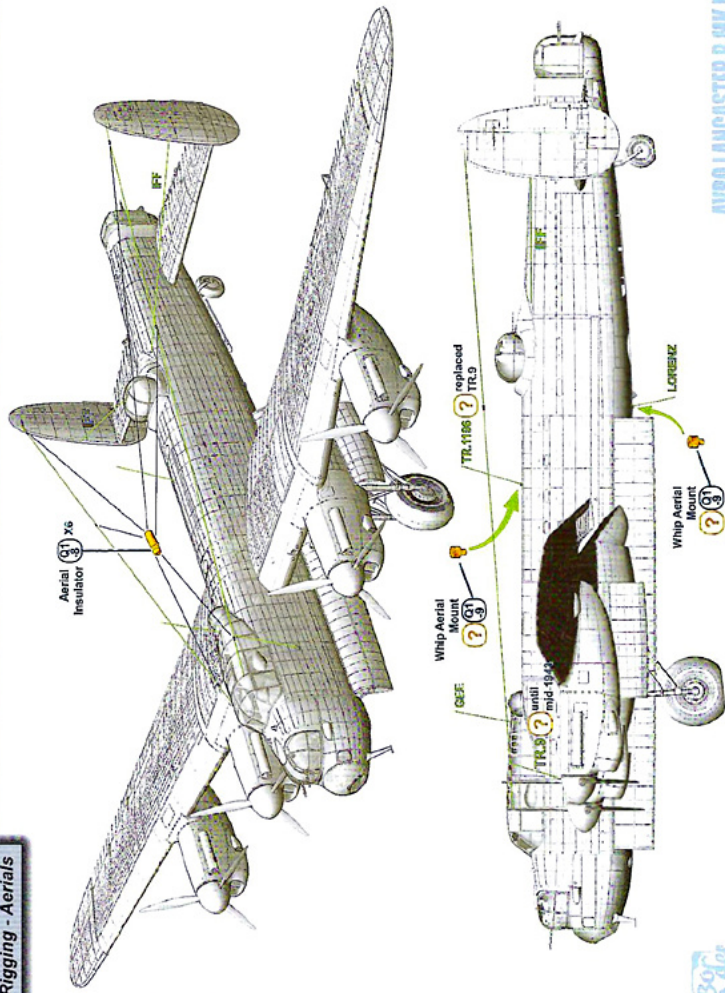

AVRO LANCASTER

B.Mk.I/III

PAINTING AND MARKING GUIDE

BORDER MODEL REF: BF-010 Avro Lancaster B.Mk.III (Phantom of the Ruhr) BO-B EEE139 550 Sqn Waltham 1944.

 AMG-0633 Rubber & Ties	 AMG-0041 Dark Rust	 AMG-0045 Gun Metal	 AMG-0016 Matt Black
 AMG-0070 Medium Brown Dark Earth (FS 40C)	 AMG-0194 Matt Aluminium	 AMG-0215 FS 34229 B5024K Interior Green	 AMG-0915 Dark Green (FS241)
 AMG-0926 Olive Drab Base			

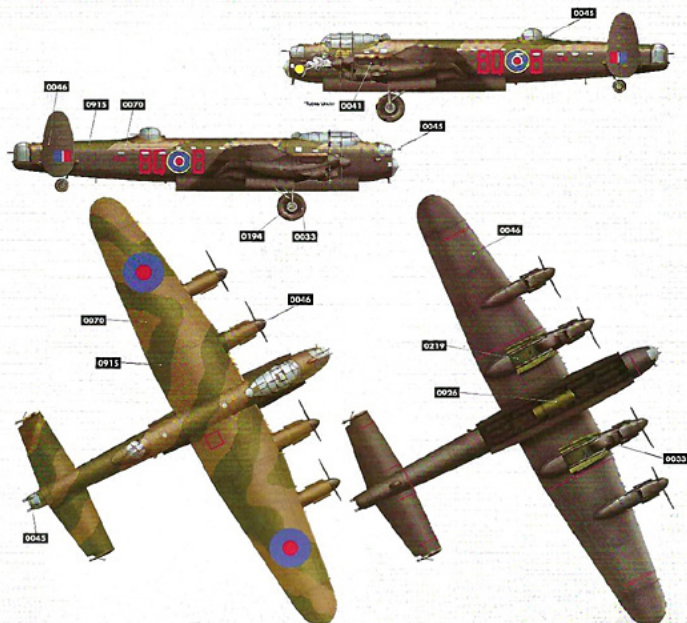

WEATHERING STEPS WITH AMMO PRODUCTS

1 PRIMER LINK WASH AMG-1614 Flat Neutral Brown for Green and Brown	2 SHADES AMG-1801 Effects Wash	3 SHADES AMG-3004 Europe Earth	4 ACRUSTIC WASH AMG-0719 Neutral Grey for lower surfaces
2 SHADES AMG-1615 Flat Stone Grey for Black	4 SHADES AMG-1003 Interior Wash	4 SHADES AMG-0708 Dark Brown for upper surfaces	

AVRO LANCASTER

B.Mk.I/III

PAINTING AND MARKING GUIDE

BORDER MODEL REF: BF-D10 Avro Lancaster B.Mk.I (Victorious Virgin) RF128 QB-W(424 Squadron). UK, March 25, 1945.

 AMIG-0033 Rubber & Tires	 AMIG-0041 Deck Paint	 AMIG-0046 Gun Metal	 AMIG-0048 Matt Black
 AMIG-0070 Medium Brown Dark Earth (E0-410)	 AMIG-0194 Matt Aluminium	 AMIG-0219 FS 31223 (E0-042) Interior Green	 AMIG-0915 Dark Olive (E5-24)
 AMIG-0528 Olive Drab Base			

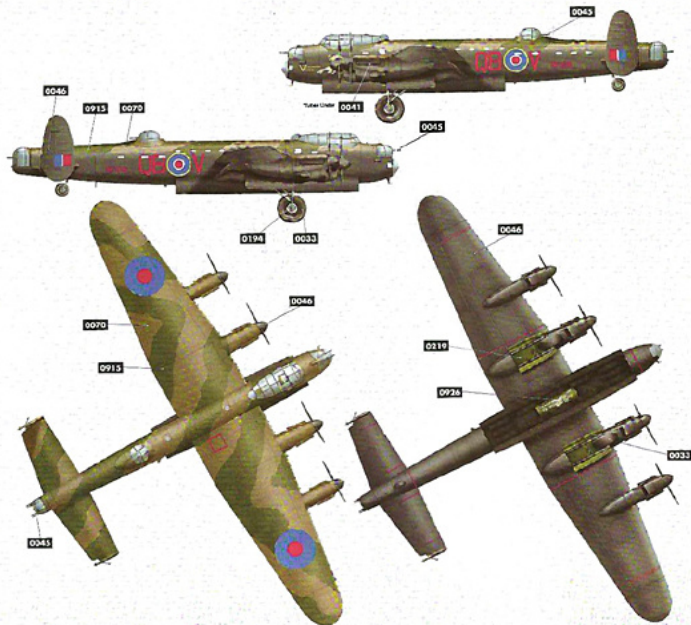

WEATHERING STEPS WITH AMMO PRODUCTS

1 PANEL LINE WASH AMIG-1614 Flat Neutral Brown for Green and Brown	2 FINE STAIN AMIG-1801 Effects Wash	3 GROUNDIT AMIG-3004 Europe Earth	7 ACRYLIC WASH AMIG-0710 Neutral Grey for lower surfaces
2 PANEL LINE WASH AMIG-1815 Flat Stone Grey for Dark	4 GROUNDIT AMIG-1003 Interior Wash	4 ACRYLIC WASH AMIG-0785 Ink Brown for upper surfaces	

AVRO LANCASTER

B.Mk.I/III

PAINTING AND MARKING GUIDE

BORDER MODEL REF: BF-010 Avro Lancaster B.Mk.III England 1944.

 AMG-0033 Rubber & Tires	 AMG-0041 Dark Rust	 AMG-0045 Gun Metal	 AMG-0048 Matt Black
 AMG-0070 Medium Brown Dark Earth (55-45)	 AMG-0194 Matt Aluminium	 AMG-0215 FS 34226 (55263) Interior Green	 AMG-0215 Dark Green (25-74)
 AMG-0926 Olive Drab Base			

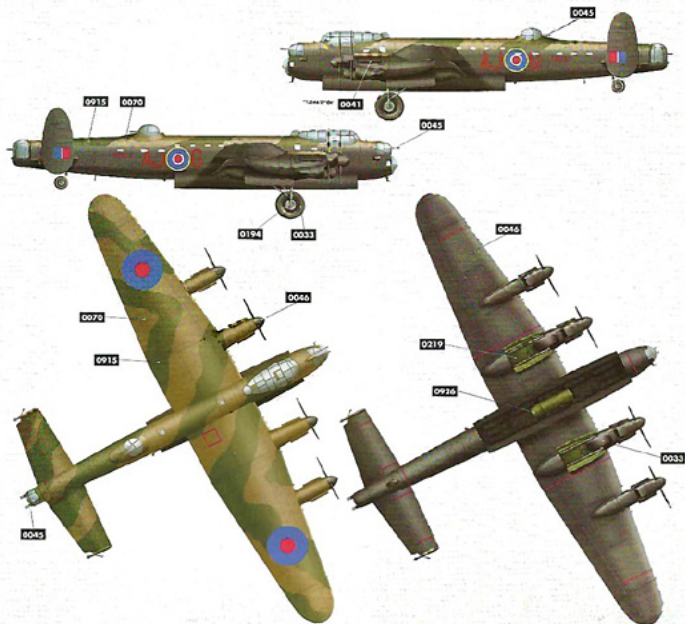

WEATHERING STEPS WITH AMMO PRODUCTS

1. PANEL LINE WEATHER

AMMO-1014 PGM Neutral Brown
for Green and Brown

2. PANEL LINE WEATHER

AMMO-1015 PGM Stone Gray for Black

3. PANEL LINE WEATHER

AMMO-1001 G3033 D3038

4. CORROSION

AMMO-1003 Interior Wash

5. CORROSION

AMMO-0804 Europe Earth

6. ACFT LINE WEATHER

AMMO-0785 Bark Brown for upper surfaces

7. PANEL LINE WEATHER

AMMO-0715 Neutral Gray for inner surfaces

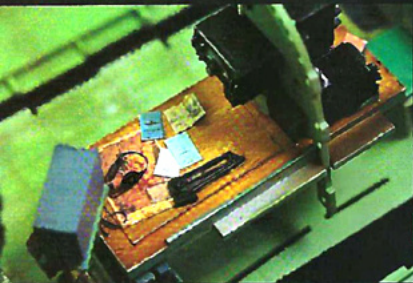
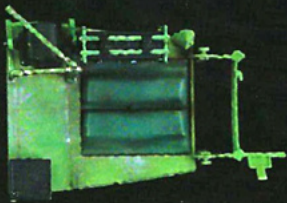
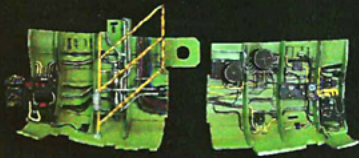

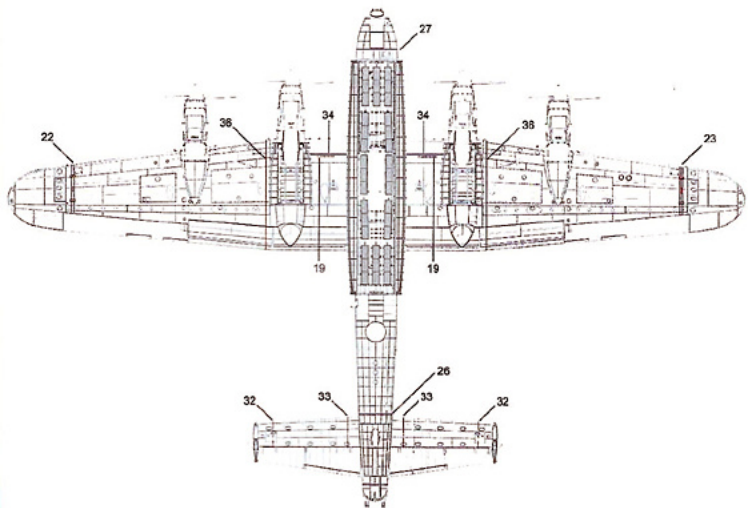
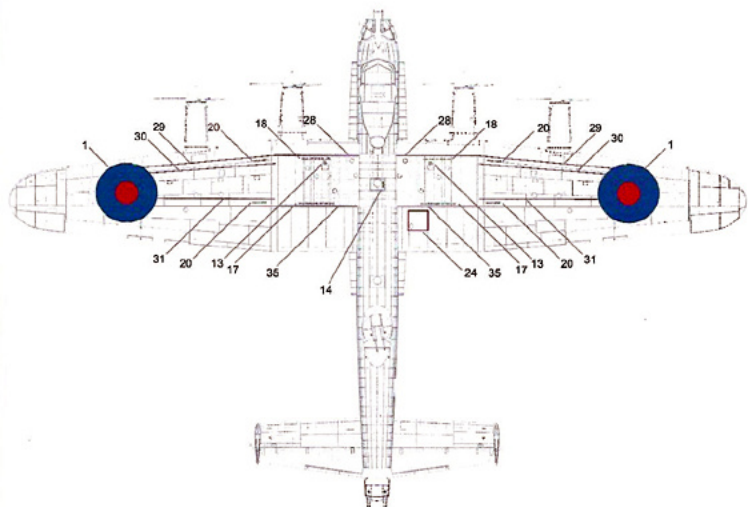

'Phantom of the Ruhr' BQ-B EE139 100 San Waltham 1944

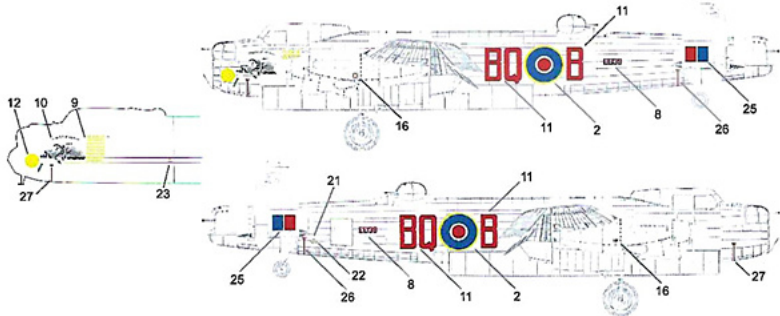

'Victorious Virgin' QB-V RF128 424 (Tiger) Squadron

